

B. TECH.
(SEM V) THEORY EXAMINATION 2018-19
MACHINE DESIGN -I

Time: 3 Hours

Total Marks: 70

- Note:** 1. Attempt all Sections. If require any missing data; then choose suitably.
2. Standard design data book is allowed.

SECTION A

1. Attempt all questions in brief.

2 x 7 = 14

- What are the factors to be considered in the selection of materials for a machine element?
- What are the methods of reducing stress concentration?
- Compare the strength of a hollow shaft with that of a solid shaft of same diameter and material of the diameter ratio of 0.5.
- Write the numbers of active turns in terms of number of total numbers of turns for different end connections of compression springs.
- Why is the efficiency of self-locking square threaded screw less than 50%?
- Describe the types of riveted joint. Also explain the various failure modes of rivets.
- Under what circumstances flexible couplings are used?

SECTION B

2. Attempt any three of the following:

7 x 3 = 21

- A shaft as shown in figure 1 is subjected to bending load of 3kN, twisting moment of 1000 N-m and an axial pull of 15 kN. Find the normal and shear stresses at point A and B.

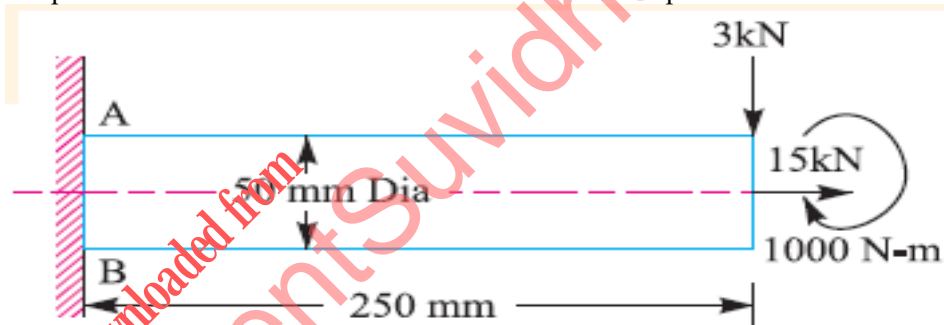

Figure-1

- A component machined from a plate made of steel 45C8 ($S_{ut} = 630$ MPa) is shown in figure 2. It's subjected to a completely reversed axial loading of 50 kN. The expected reliability is 90% and the factor of safety is 2. The size factor is 0.85. Determine the plate thickness t for infinite life, if the notch sensitivity factor is 0.8.

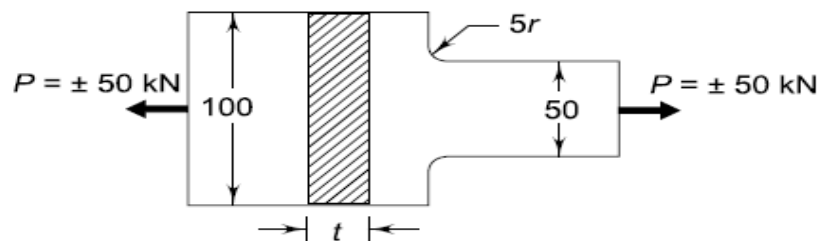

Figure 2

- Define the efficiency of riveted joint? A steam boiler is to be designed for a working pressure of 2.5 MPa with its inside diameter 1.6 m. Give the design calculations for the longitudinal joints. The permissible stresses are $\sigma_t = 75$ MPa, $\tau_s = 60$ MPa and $\sigma_c = 125$ MPa.

- d. It is required to design a helical compression spring subjected to a maximum force of 1250 N. the deflection of the spring corresponding to the maximum force should be approximately 30 mm. the spring index can be taken as 6. The spring is made of patented and cold drawn steel wire. The ultimate tensile strength and modulus of rigidity of the spring material are 1090 and 81370 N/mm² respectively. The permissible shear stress for the spring wire should taken as 50% of ultimate tensile strength. Design the spring and calculate:
- Wire diameter
 - Mean coil diameter
 - Active number of coils
 - Total number of coils
 - Free length of the spring
 - Pitch of the coil
- e. Design a protective type of cast iron flange coupling for a steel shaft transmitting 15 kW at 200 rpm and having an allowable shear stress of 40 MPa. The working stress in the bolts should not exceed 30 MPa. Assume that the same material is used for the shaft and key and that the crushing stress is twice the value of its shear stress. The maximum torque is 25% greater than the full load torque. The shear stress for cast iron is 14MPa.

SECTION C

3. **Attempt any one part of the following:** 7 x 1=7
- What do you understand by preferred sizes? It is required to standardize load-carrying capacities of dumpers in a manufacturing unit. The maximum and minimum capacities of such dumpers are 40 and 630kN. The company is interested in developing seven models in this range. Specify their load-carrying capacities.
 - A mild steel shaft of 50 mm diameter is subjected to a bending moment of 2000 N-m and a torque T. If the yield point of the steel in tension is 200 MPa, find the maximum value of this torque without causing yielding of the shaft according to 1. The maximum principal stress; 2. The maximum shear stress; and 3. the maximum distortion strain energy theory of yielding.
4. **Attempt any one part of the following:** 7 x 1=7
- A cantilever beam made of cold drawn steel 20C8 ($S_t = 540 \text{ N/mm}^2$) is subjected to a completely reversed load of 1000 N as shown in below fig.3. The corrected endurance limit for the material of the beam may be taken as 123.8 N/mm². Determine the diameter "d" of the beam for a life of 10000 cycles.

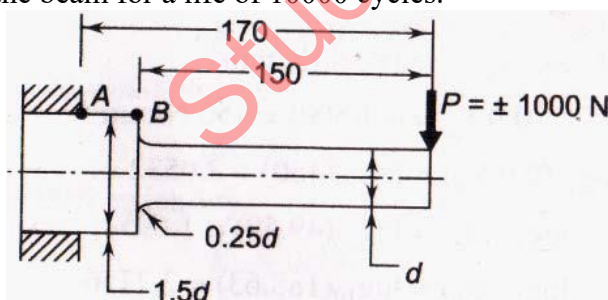

Fig.3

- A bracket is riveted to a column by 6 rivets of equal size as shown in following fig.4. It carries a load of 60kN at a distance of 200 mm from the column. If the maximum shear stress in the rivet is limited to 150MPa, find the diameter of the rivet.

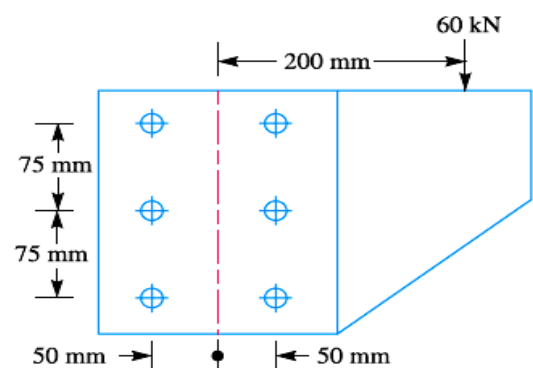

Fig.4

5. Attempt any one part of the following:

7 x 1=7

- a. A transmission shaft supporting a spur gear B and a pulley D is shown in figure 5. The shaft is mounted on two bearings A and C. The diameter of pulley and the pitch circle diameter of gear are 450 and 300 mm respectively. The pulley transmits 20 kW power at 500 rpm to the gear. P_1 and P_2 are belt tensions in tight and loose sides, while P_t and P_r are tangential and radial components of gear tooth force. Assume, $P_1 = 3P_2$ and $P_r = P_t \tan 20^\circ$

The gear and pulley are keyed to the shaft. The material of the shaft is steel 50C4 ($S_{ut} = 700 \text{ N/mm}^2$ and $S_{yt} = 460 \text{ N/mm}^2$). The factors K_b and K_t of ASME code are 1.5 each. Determine the shaft diameter using ASME code.

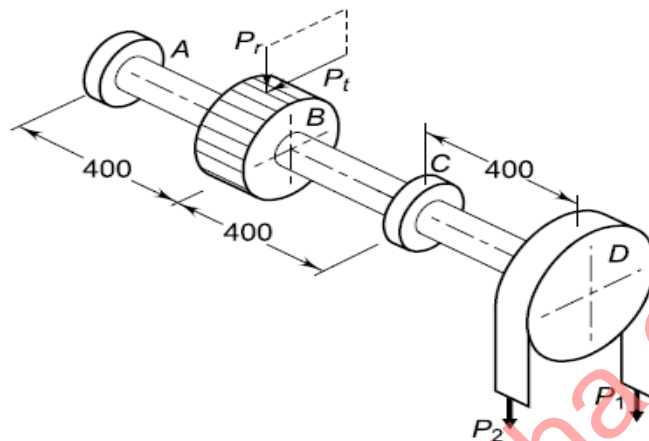

Figure 5

- b. A mild steel shaft transmits 20 kW at 200 rpm. It is subjected to a bending moment of 562.5 N-m. Determine the size of the shaft, if the allowable shear stress is 42 MPa, and the maximum tensile or compressive stress is not to exceed 58 MPa. What size of the shaft will be required if it is subjected to gradually applied load?

6. Attempt any one part of the following:

7 x 1=7

- a. It is required to design square key for fixing a gear to transmit a torque of 198943.68 N-mm. The key is made of plain carbon steel having the yield point in tension and in compression as 460 MPa and factor of safety 3. Determine the dimensions of the key.
- b. Design a spring for a balance to measure 0 to 1000N over a scale of length 80 mm. the spring is to be enclosed in a case of 25 mm diameter. The approximate number of turns is 30. The modulus of rigidity is 85 GPa. Also calculate maximum shear stress induced.

7. Attempt any one part of the following:

7 x 1=7

- a. Name the various components of the screw jack and their usual materials. A single start square threaded screw of mean diameter 24 mm and pitch of 5mm is tightening by screwing a nut whose mean diameter at bearing surface is 50 mm. If the coefficient of friction between the nut and screw is 0.1 and for the nut and bearing surface is 0.16. Find the force required at the end of a spanner 0.5-meter-long when the load on the screw is 10 kN.
- b. Describe the various forms of the threads used for power screw, giving their merits and demerits. Discuss the procedure for the design of the screw having square threads.